

SALES DRAWING

SALES DRAWING

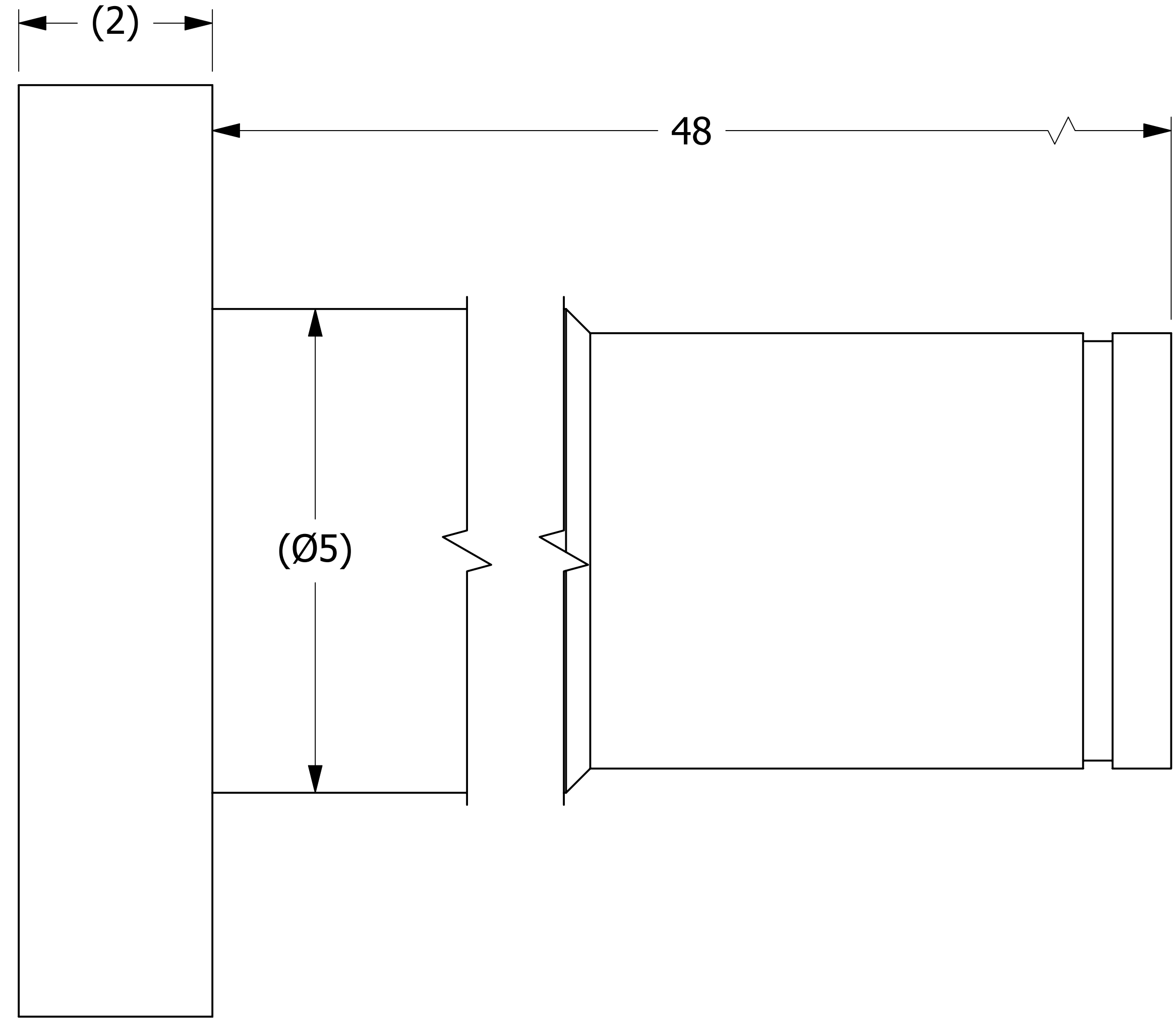
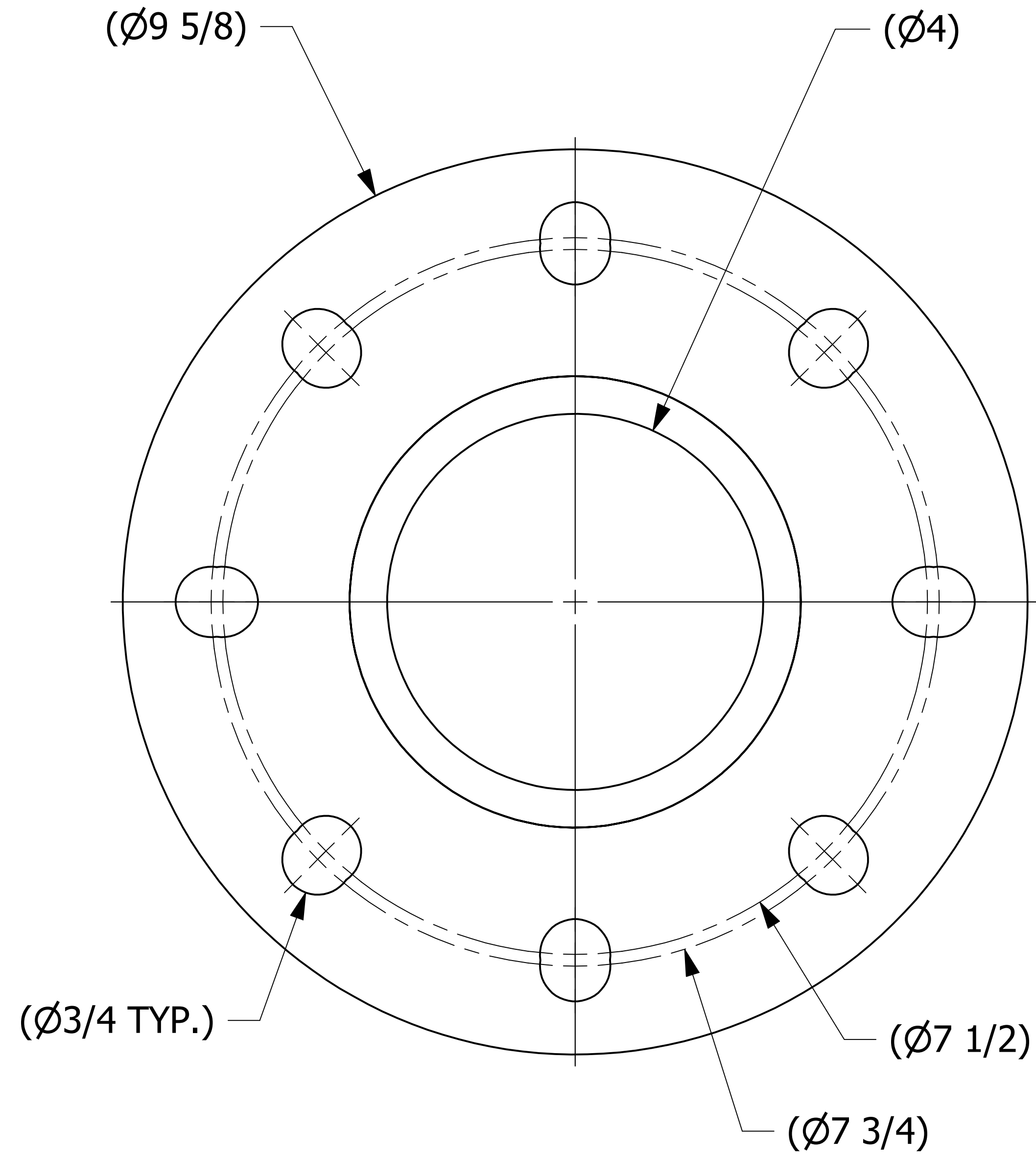

C	GDS	7-27-11	ADDED MARKING PRESSURE NOTE
B	VD	09-03-10	CHANGED PART # HS4DT4548BK TO HS4PST4548BK. CHANGED DESCRIPTION. REPLACED HS4DTFL W/ HS4FLDGS2.
A	CHL	12-9-09	NEW PART ADDED TO SYSTEM
REV	BY	DATE	DESCRIPTION

UNLESS OTHERWISE SPECIFIED DIMENSIONAL TOLERANCES FRACTIONAL: ±1/16 X.XX: ±.03 X.XXX: ±.015 ANGULAR: ±1° DEBURR ALL SHARP EDGES. ALL MACHINED SURFACES TO HAVE A 125 RMS FINISH UNLESS NOTED OTHERWISE. THIRD ANGLE PROJECTION	DRAWN BY:	PJG
	CHECKED BY:	VD
	PROTOTYPE BY:	PJG
	PROTOTYPE DATE:	8/20/2009
	APPROVED FOR PRODUCTION BY:	PJG
	PRODUCTION DATE:	12/9/2009

PART NAME: PIPE STUB 4"		
MATERIAL: SALCO PE		
PROJECT #: 090428	SHEET #: 1 OF 1	SCALE: 1:1
DRAWING #: D27366	PART #: HS4PST4548BK	

THIS PRINT, PROPERTY OF SALCO PRODUCTS INC. CONTAINS PROPRIETARY INFORMATION AND MUST NOT BE COPIED, REPRODUCED, OR USED DETRIMENTALLY TO OUR INTEREST.